

ALLISON Transmission Controls (COBRA - NG Series)

ALLISON 1000/2000 Series (24V) – RIGHT HAND

Allison™ 1000/2000 NG Shift Systems

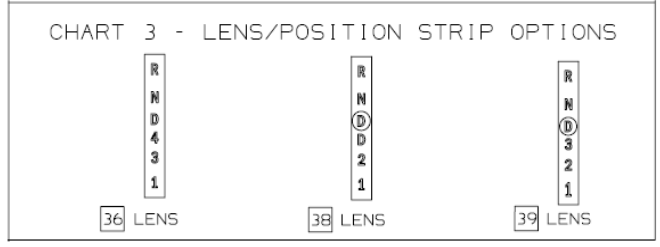

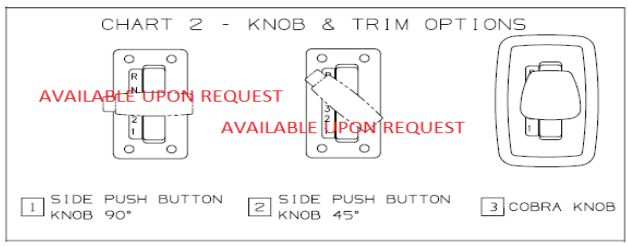
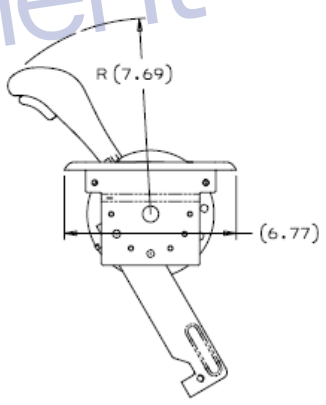
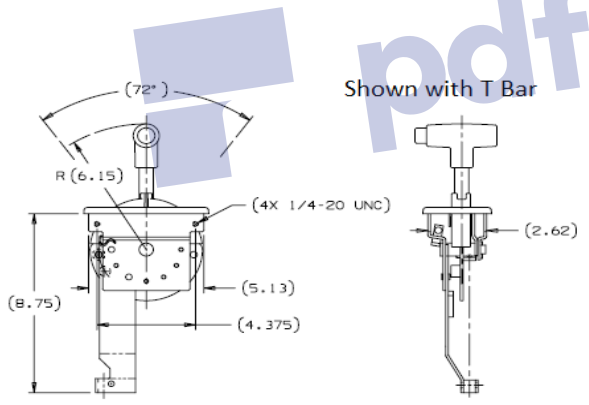
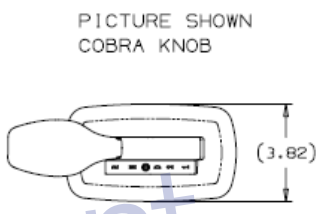
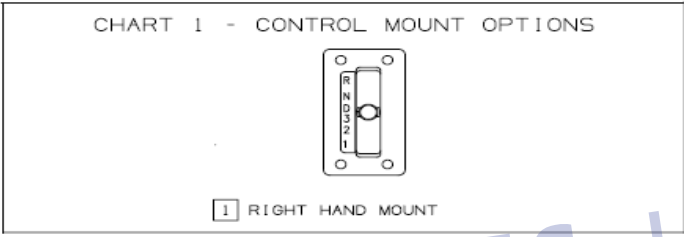
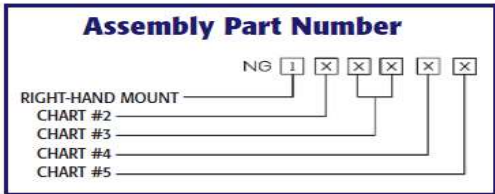
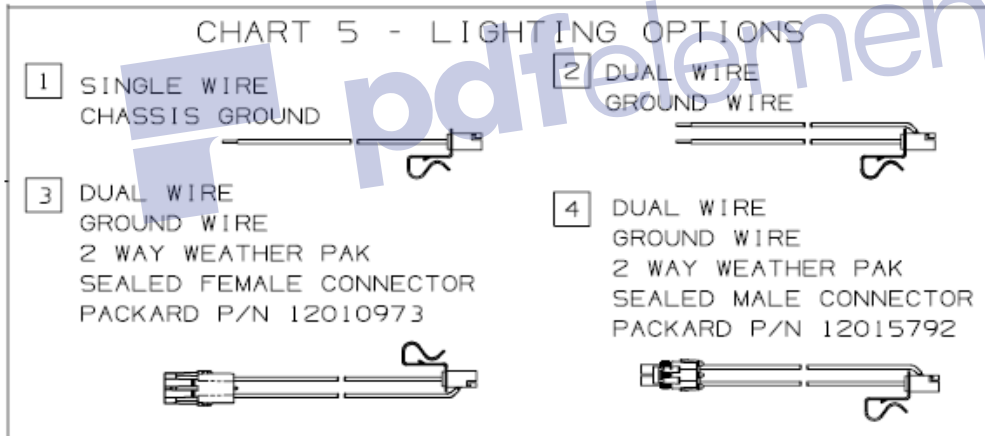
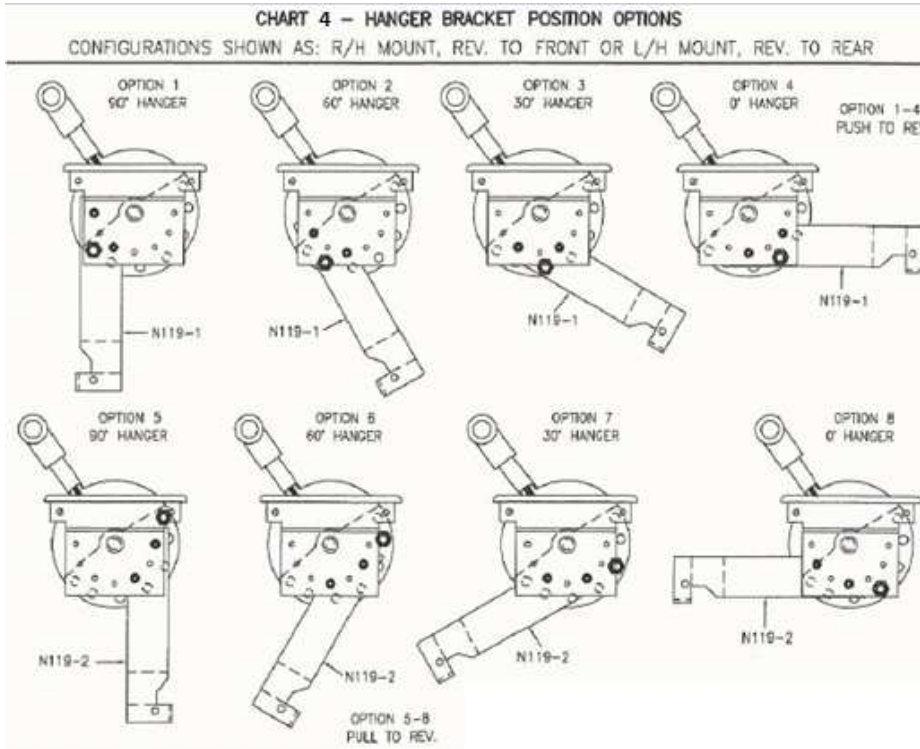

ALLISON 1000/2000 Series (24V) – LEFT HAND

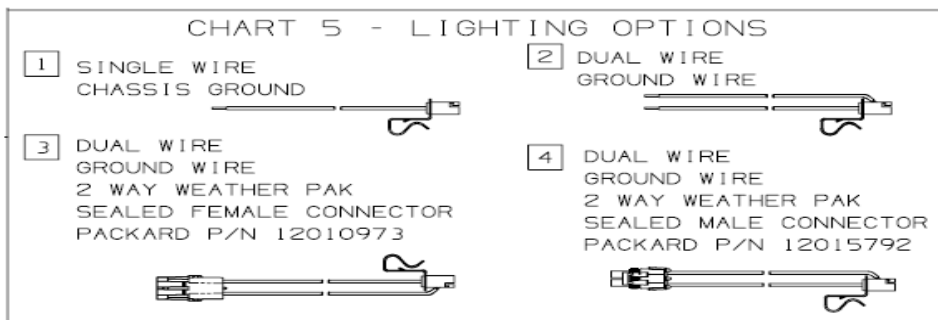
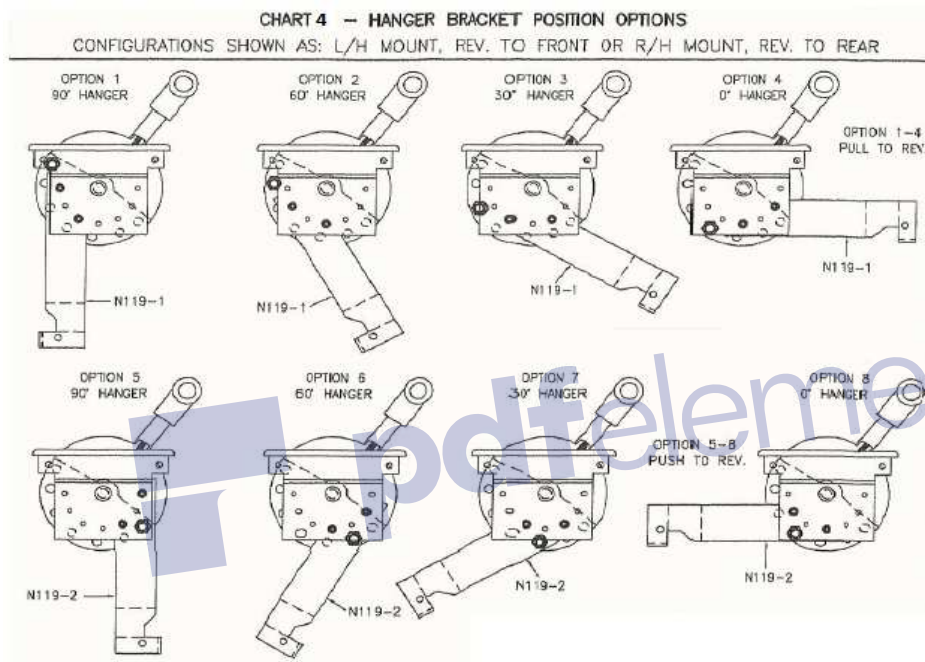
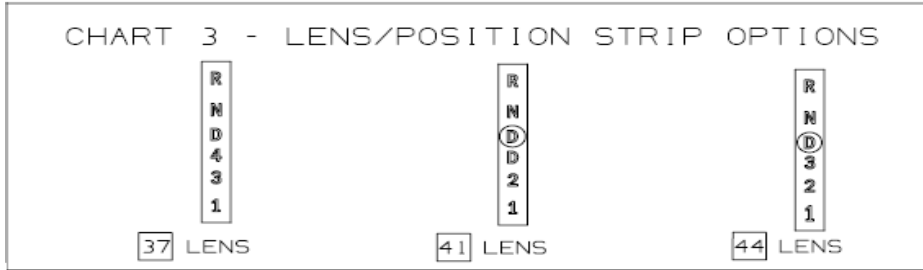

1K/2K Transmission Kits for use with "NG" Style Shifters

Standard Shift Arm Rad for NG is 2.74"

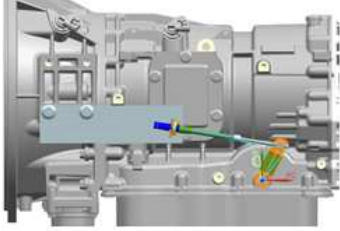
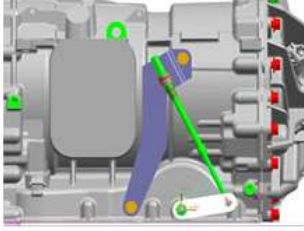
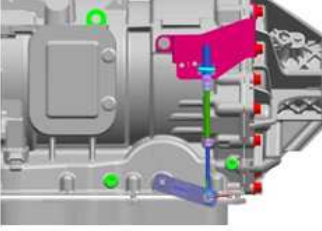
		
<p>59572 Application: With "Reverse Only" Configuration: "Push into Reverse" Cable Req.: 4 Ser. 2.5 Travel C-Hub Notes:</p>	<p>59561 Application: With "Reverse Only" Configuration: "Push into Reverse" Cable Req.: 4 Ser. 3.5 Travel C-Hub Notes: Do not use on pre 2007 models using Rev/Net switch option</p>	<p>59581 Application: With "Reverse Only" Configuration: "Push into Reverse" Cable Req.: 4 Ser. 2.5 Travel C-Hub Notes:</p>

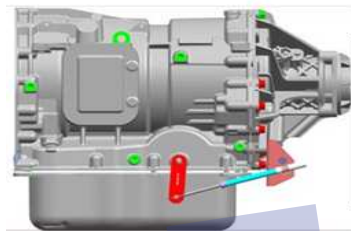

59571
Application: With "Reverse Only"
Configuration: "Push into Reverse"
Cable Req.: 4 Series 2.5 Travel C Hub
Notes: Rear Entry, Ref 59560 Style